

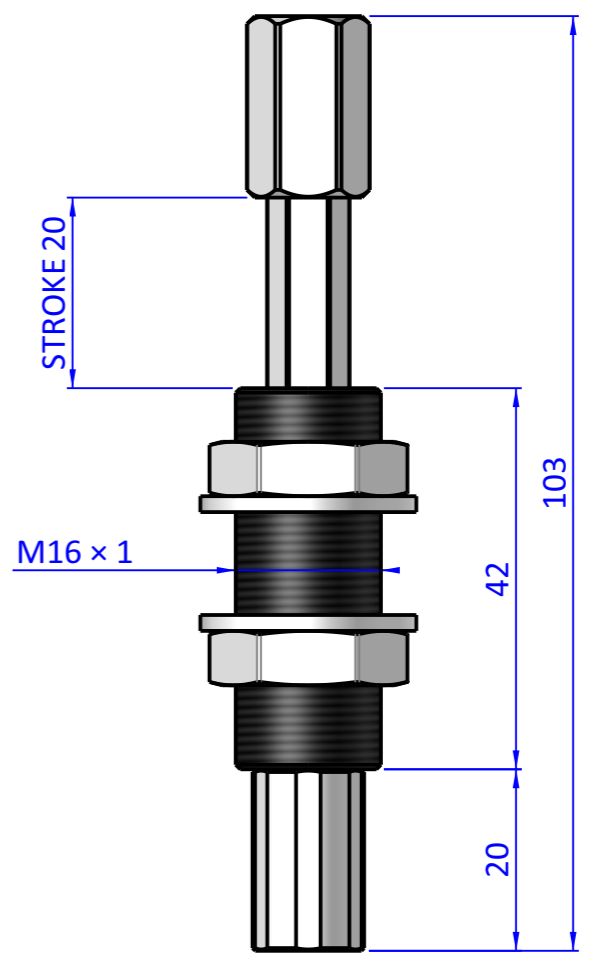

THE PROPERTY OF THE DRAWING IS ESTABLISHED BY LAW. IT IS FORBIDDEN TO PRODUCE OR SHOW IT TO THIRD PART. WITHOUT A WRITTEN AGREEMENT.

Item	Name	Q.ty
1	D.M16X1	2
2	M.8.45X34	1
3	R.16.SCH	2
4	VSN.14.1	1
5	VSN.14.2	1
6	VSN.1420.4	1
7	VSN.1420.3	1
8	VSNG.1620.2.1	1

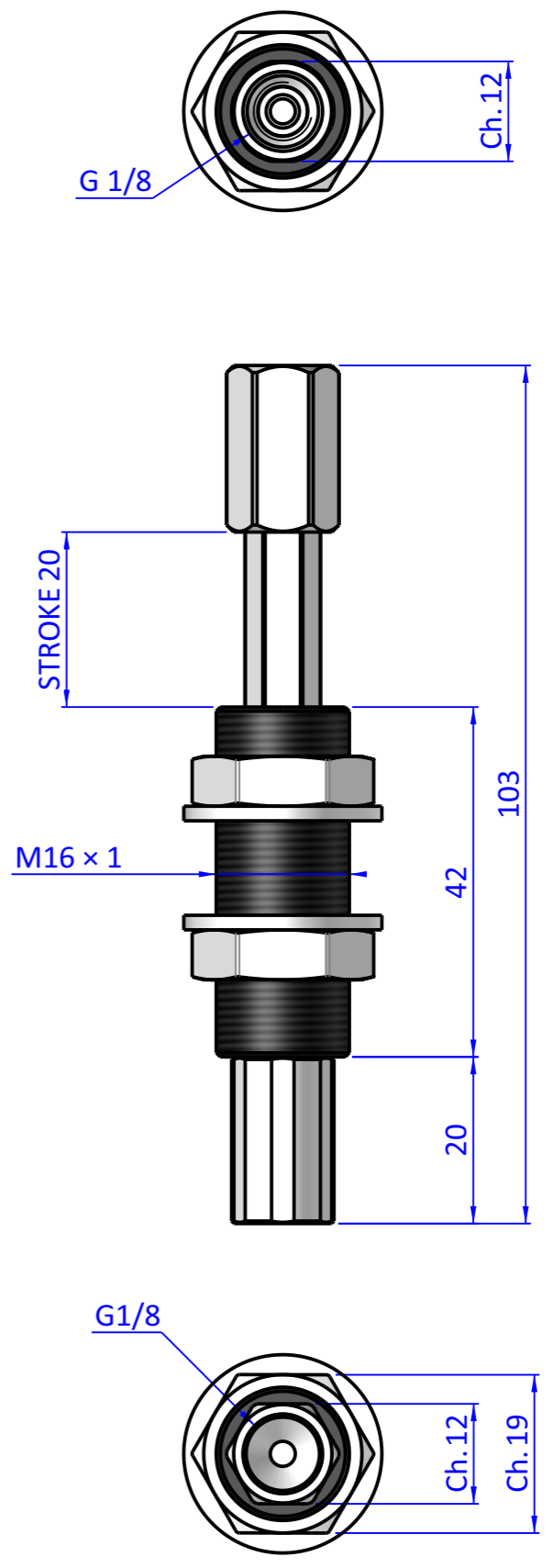
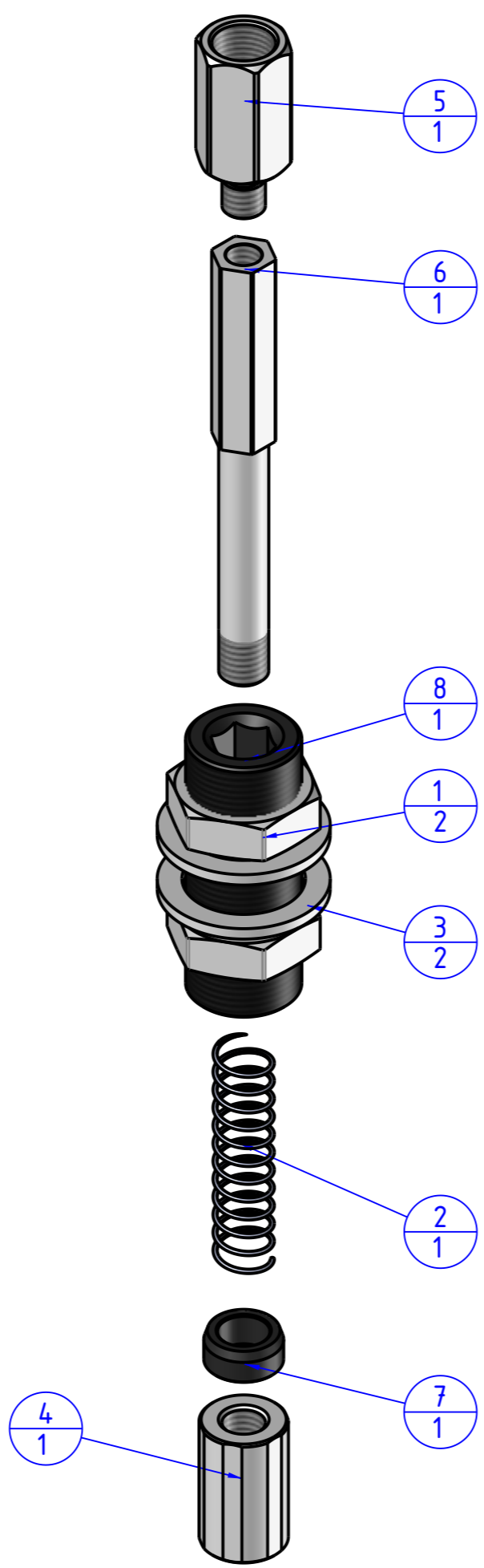

Format A3
UNI 936-76

 FPS SERVICES AUTOMATION		DESIGNED FROM		REVIEW
		FPS Automation		A
GENERAL TOLERANCE		DATE	WEIGHT	
UNI - ISO 2768		31/03/2026	0,041kg	
CLASSE f		DESCRIPTION	CODE	
		CA.SDNG.1620	CA.SDNG.1620	